

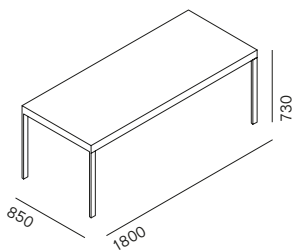

Jean Nouvel definisce la figura dell'architetto / progettista come colui che, osservando i cambiamenti culturali, storici e ambientali, riesce a tradurre tali tendenze in progetto, con una valenza altamente poetica. E l'elemento poetico è proprio insito nel design del tavolo Grand Ecart, poiché integra il minimalismo dell'oggetto con il meraviglioso caos degli ospiti inattesi. La famiglia di tavoli Grand Ecart prevede quindi versioni allungabili e versioni fisse.

Jean Nouvel defines the figure of the architect / designer as the one who, by observing cultural, historical and environmental changes, succeeds in translating these trends into a design with a highly poetic value. The poetic element is certainly intrinsic to the design of the Grand Ecart table, as it incorporates the object's minimalism with the welcomed chaos of unexpected guests. The family of Grand Ecart tables therefore offers both extending versions and fixed versions.

A



B

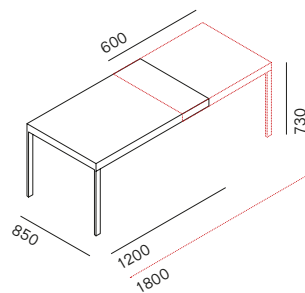

C

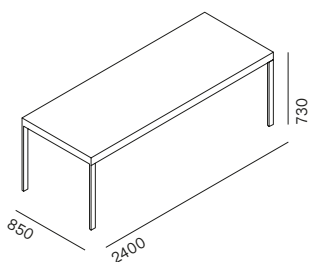

D

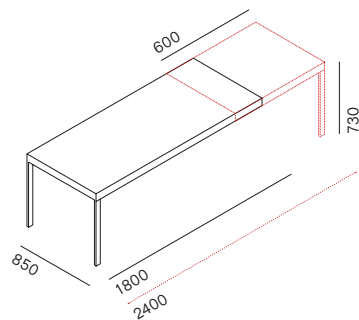

E

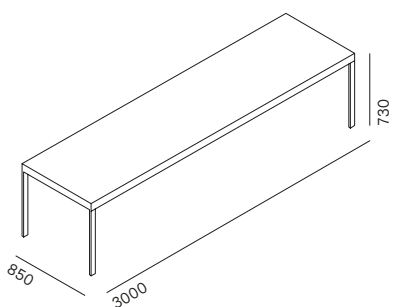

F

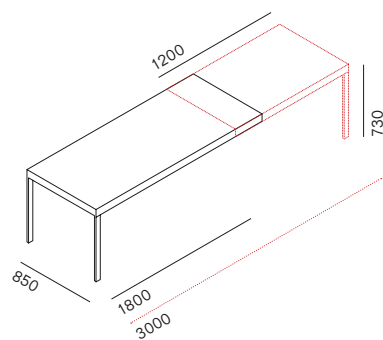

Prodotto
Product

Grand Ecart

A C E

Tipologia
Type

Tavoli fissi

Fixed tables

Grand Ecart

B D F

Tavoli allungabili

Extendable tables

Finitura
Finishes

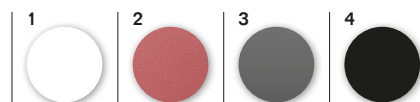

1 Alluminio verniciato bianco opaco / Matt white lacquered aluminium 2 Alluminio verniciato rosso opaco / Matt red lacquered aluminium 3 Alluminio verniciato grigio opaco / Matt grey lacquered aluminium 4 Alluminio verniciato nero opaco / Matt black lacquered aluminium